



## **PEDESTRIAN GAS SPRING GATE / DOOR CLOSER**

### **INTRODUCTION**

The Gas Spring Closer is entirely self contained and is pre-charged with high pressure nitrogen gas to give the closing force.

The unit also has a chamber pre-filled with oil, to provide a controlled rate of movement through the total stroke length during opening and closing.

This combination eliminates the normal speeding up and crashing impact on closing, without rebound.

The closer is supplied with a maximum pressure to provide a high extension force. For most applications this will need to be reduced as described under a separate paragraph pressure adjustment in the installation instructions.

### **APPLICATIONS**

The most popular use of the gas spring closer is safe and assured closing of pedestrian gates in various applications. The unit may be used in association with security locking devices to provide assurance that the gate/door closes and meets with the lock securely.

### **LIFE EXPECTANCY**

The life expectancy of the unit is dependent upon the way it is applied, the frequency of its use and external influences e.g.) abuse or vandalism environmental conditions.

The most common cause of failure is piston damage if open and close stops are not employed. Piston rod damage or end seals if side loads are applied by misalignment or fouling in operation. Abuse by forcing the unit beyond normal operation or by stepping onto or pulling the unit.

It is advised that the unit be installed at high level or a guard affixed over the unit to prevent damage from abuse in certain environments.

### **PLEASE NOTE**

Units may only be recharged or have pressure added by Tringmain Security.  
Tampering with the units over and above the normal set up procedure is dangerous and will invalidate warranty and may result in injury.

## INSTALLATION NOTES GAS SPRING CLOSER

Installation of the closer unit is carried out by first assessing the gate or door to which the unit is to be installed. The following criteria should be observed.

- There is sufficient clearance behind the door / gate for the unit once open.
- The door / gate leaf is no shorter than 770mm from centre of hinge point.
- Geometry for rear bracket installation is achievable.

The Gas Spring Closer may be installed on steel or timber doors. When installation is for a steel gate / door with a steel hinge post the standard mounting brackets supplied can be used and welded in position. The rear and front brackets are supplied 85mm long from hole centre. These can be cut down or extended to suit the requirements. When used with timber gates / doors the brackets will require be welding to patch plates of appropriate size and bolting to the timber gate and support structure.

1. Choose a position for installing the gas spring closer on the gate / door. This should be preferably along a horizontal stile. It is important that the gas closer is mounted in the horizontal plane in both open and close positions of the gate to prevent water ingress into the piston rod shroud.
2. Once a position has been determined, with the gate closed to the close stop, a line should be drawn using a spirit level across the gate / door and hinge support structure to denote mounting positions for the rear and front brackets.
3. The rear bracket should be installed first. Measure a position 120mm away from the gate hinge horizontally and mark on the support structure (see figure). This will represent the pivot hole and fixing point of the closer. Now place the rear bracket on the mark and measure 120mm in the other plane to the pivot hole. Cut or extend the bracket where required.
4. The rear bracket may now be affixed to the gate support post, (ensure that the bracket is fixed 16mm below the horizontal line marked earlier) this will make the centre of gas spring follow through the line.
5. Measure 770mm from the rear mounting point, and mark clearly a vertical line position for the front mounting bracket. Ensure the gate / door is fully closed to the closing stop.

6. The front mounting bracket may now be attached to the gate (ensure that the bracket is fixed 16mm below the horizontal line and the vertical line passes through the centre of the 10mm hole. The bracket will require cutting to size to give a closing angle.
7. Install the gas spring closer onto the brackets using the M10 nuts provided.
8. Push on the gate to test the opening pressure required to open it.

**In most cases the force will be too strong, & adjustment will be required...**

## **PRESSURE ADJUSTMENT**

Disconnect the gas spring at the smaller diameter end by unlocking the 10m nut. Unscrew anti-clockwise the ball joint assembly until it separates from the 8mm threaded shaft. Located down the centre of this threaded shaft is a valve. This valve when pressed releases the gas. Quick operation is required to allow re-closure of the valve to prevent excess loss of gas.

## **RECOMMENDED PRESSURE ADJUSTMENT TOOL**

For best results this can be provided by Tringmain at a small additional cost. The tool is a round knob with a central pin surrounded by an 8mm female thread.

The knob is screwed clockwise onto the 8mm male gas spring thread. This can be done quite casually until the flat face of the knob is within 3/8" or 10mm of the end face of the gas spring.

**At this point, extreme care must be taken with small increments of turn and at approximately 5/16 and gas will be heard to release.  
On sound of release of a small amount of gas.**

**It is important to be ready to turn back anti-clockwise instantly to seal the valve.**

Remove the adjustment tool anti-clockwise and refit ball joint. Connect back to the fixing bracket and tighten the 10mm nut. Now test the opening and closure of the gate. Should further gas require venting repeat the procedure.

**AT ALL TIMES TAKE CARE TO KEEP FACE AND EYES AWAY  
TO PREVENT INJURY.**

**PRESSURE ADJUSTMENT WITHOUT SPECIAL TOOL**

1. Remove the gas spring from the gate.
2. Rotate the ball joint at the smaller diameter end of the gas spring anticlockwise and remove.
3. Now revealed is the 8mm threaded shaft with a 3mm dia. hole down which is the gas release valve. Place a steel pin of approx. 2.5mm diameter into this hole (an ordinary nail of 2.5mm diameter ground flat at the end can be used for this purpose).
4. Hold the gas spring vertically with the piston rod downwards. Using a small hammer (of about 200 gms weight) gently tap the pin using light 'springy' strokes. This will allow a small amount of gas to escape from the gas spring. Note it is imperative that you avoid pressing the valve pin for longer than necessary otherwise you will allow an excessive quantity of gas to escape. Be sure to use only **SHORT LIGHT SPRINGY** hammer strokes to release a small quantity of gas.
5. After a few hammer strokes (3 maximum) re test the gas spring on the gate to check if the force is now reduced to the required level. If the force is still too high bleed off a little more gas pressure by repeating steps 3 to 5 as above.

**IMPORTANT NOTE**

Be very careful not to release too much gas pressure from the gas spring. If this does happen the spring can be returned to Tringmain for gas recharging at a nominal cost.

**OPEN STOP**

When satisfied with the opening and closing forces a stop must be fitted to prevent the gas spring reaching the end of the inward stroke. Move the gate full open slowly and mark the ground. At this point install the open stop in advance of the mark so that all impacts are absorbed by the ground stop and not the piston bottoming out.

**CLOSE STOP**

This should be fitted in advance of the gas spring installation. It is recommended after the installation of the gas spring a rubber fascia should be fitted to prevent the gas piston bottoming out on closure by the rubber thickness. The rubber fascia will also ensure a silent operation during use.

## GAS ADJUSTMENT

### Caution

Please read carefully before installing.

Gas Springs are filled with Nitrogen gas at high pressure and under no circumstances should they be opened or tampered with, or subjected to excessive heat or tension.

### Installation Instructions

For standard applications we recommend the use of Ball Joint fittings to alleviate any possible side load.

Always ensure that any fittings used are securely fastened onto the gas spring. Where ever possible fit with the rod down.

### Adjustment Instructions

Caution: Gas Springs are filled with Nitrogen gas under high pressure. It is recommended to use extreme caution to avoid personal injury. Use safety glasses and avoid pointing the gas spring at yourself or other persons while adjusting.

1. Remove rear fitting from gas spring. The adjusting valve is inside the thread that takes the rear fitting.
2. The internal valve is a "Schrader" type of valve as used on a car tyre.
3. To adjust the gas spring to give the correct force, hold the gas spring with the rod vertically downwards.
4. Screw the adjusting knob onto the exposed thread where the rear fitting is removed and carefully continue to screw clockwise until the Schrader valve is engaged.
5. An additional slight turning of the knob will now open the Schrader valve and gas will be released from the gas spring.
6. Care should be taken as only a slight amount of gas needs alter the working force of the gas spring.
7. Having released a small amount of gas from the gas spring turn the adjuster anticlockwise allowing the valve to close.
8. The adjuster should be removed and the gas spring reassembled for checking for suitability.
9. If the force is still too high then you will need to repeat the adjustment procedure until the correct setting is achieved. This might take two or three attempts.
10. If you find that you have released too much gas you can return the gas springs to Tringmain Security for re-gassing at a nominal charge.

GAS ADJUSTMENT KNOB

**Gas  
Adjustment  
Knob.  
(Optional)**

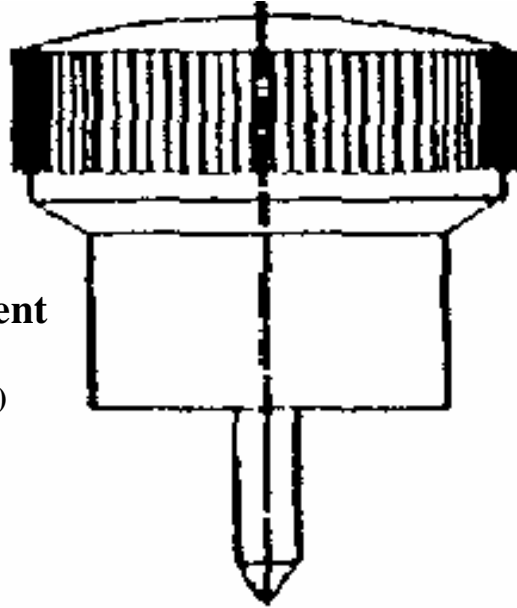

**Gas Strut  
End Valve**

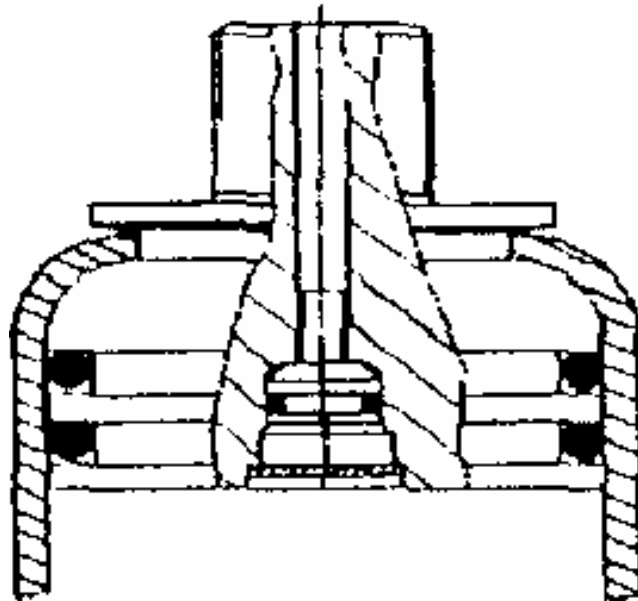

# FIXING BRACKETS

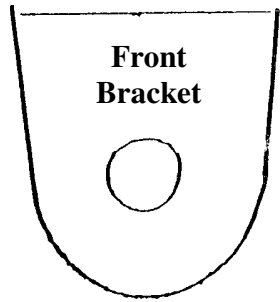

**Shown Approx  
Actual Size**

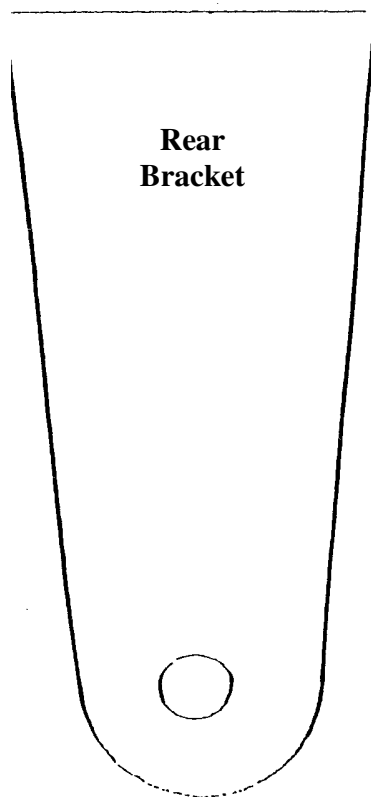

# GAS STRUT DIMENSIONS

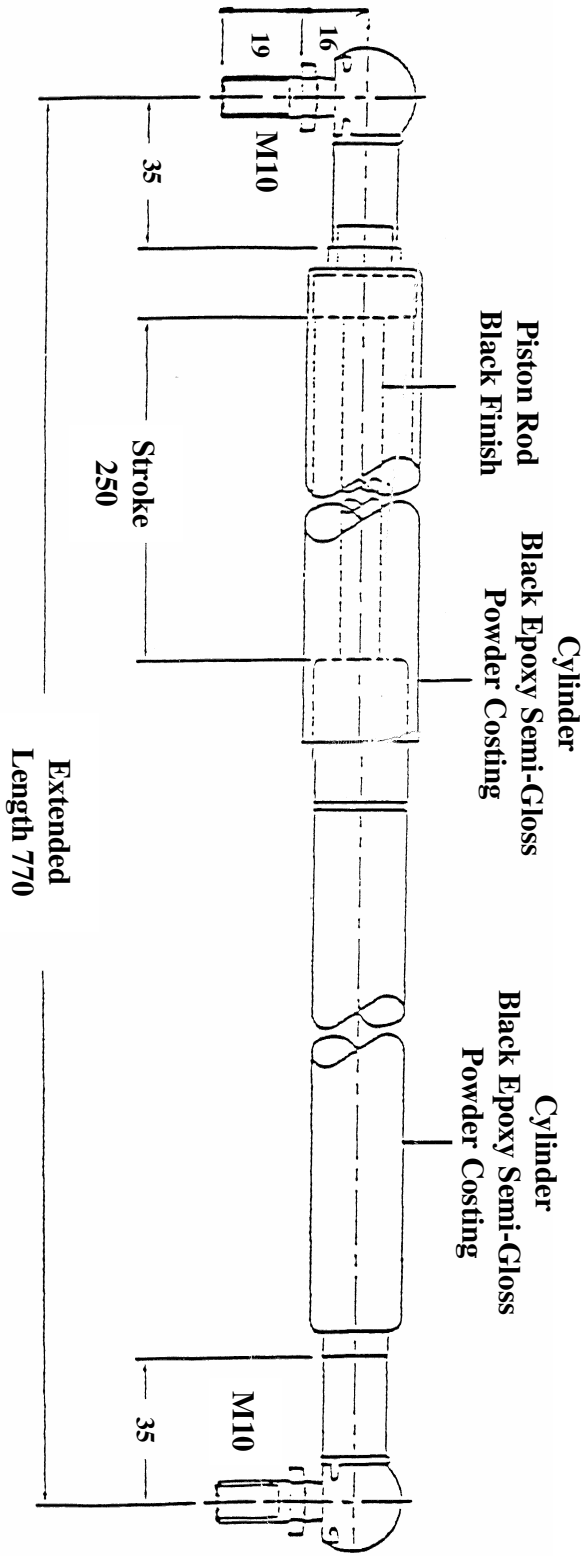

# GAS STRUT BRACKET INSTALLATION (PLAN VIEW)

